

MODELLING GUIDELINES

BEEWELCOME...

... to the celebration of creativity with 3D desktop printing!

We have some relevant information to give you.

Even though you have the potential to make real all your creativity, the art status of 3D desktop printing recommends you take into account your own limitations in preparing your 3D models. In this document we'll be presenting some of the limitations you should keep in mind.

If you're starting out in 3D modelling, we recommend you start off by designing smaller objects that don't use up the full potential of the BEETHEFIRST printer. That way it will be quicker and easier to get to know the printer's performance and to adapt your models to the quality you really want. When you feel you're no longer a novice, we suggest you take BEETHEFIRST to the limit and tell us about your work.

3D MODELLING GUIDELINES

FILE TYPE

The type of 3D files you'll need to print on BEETHEFIRST must be in STL format ([https://en.wikipedia.org/wiki/STL_\(file_format\)](https://en.wikipedia.org/wiki/STL_(file_format))).

If you're working with 3D CAD software, you'll have to export the 3D model to an STL format, in high resolution if possible.

PRECAUTIONS TO TAKE WHEN MODELING IN 3D

The 3D model cannot be composed by overlapping various models (figure 1).

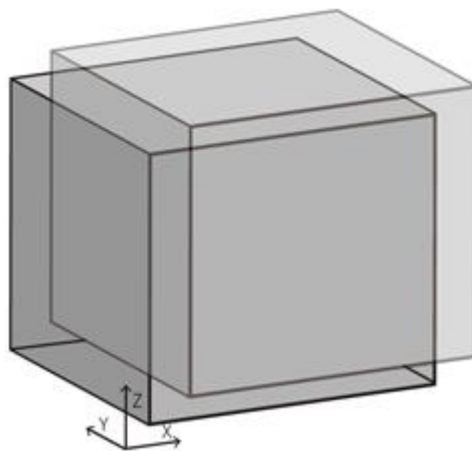

In addition, all surfaces of the 3D model ("mesh") must be closed, otherwise it won't be possible to print it (figure 2).

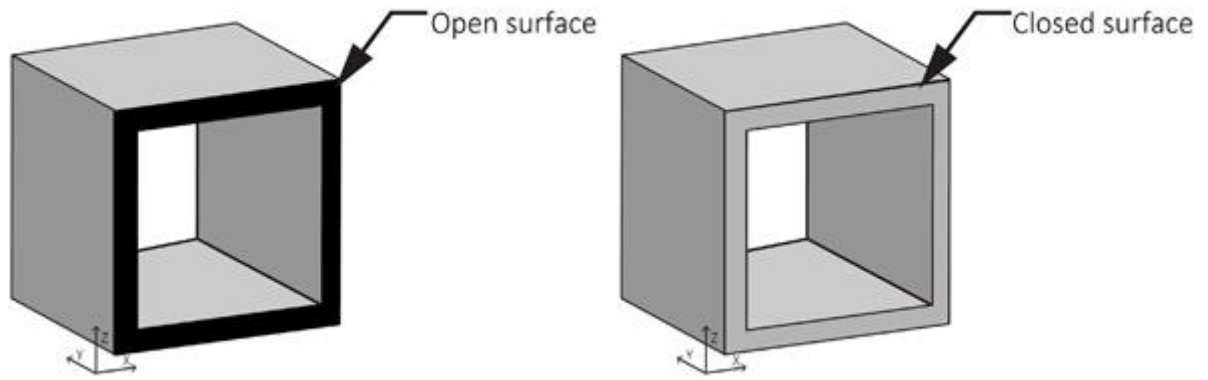

Separate Margins

If you wish to print more than one 3D model at the same time, then the models should not have shared margins (figure 3a), and we advise a gap between the objects of a minimum of 0.1mm.

On the other hand, if you wish to print the objects joined up, then their contact area must be sufficiently strong (figure 3b). Otherwise, if the connection is too superficial, the objects may easily come apart.

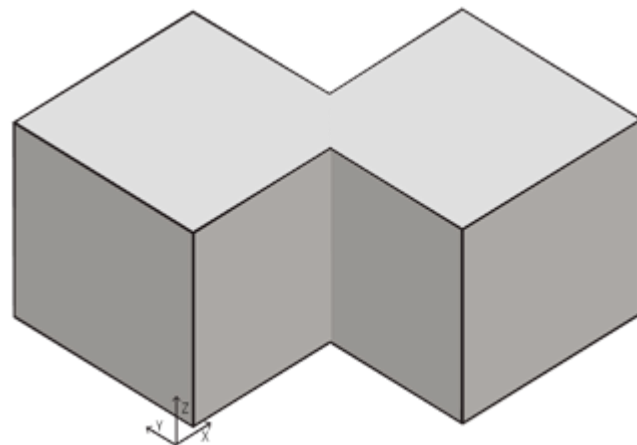
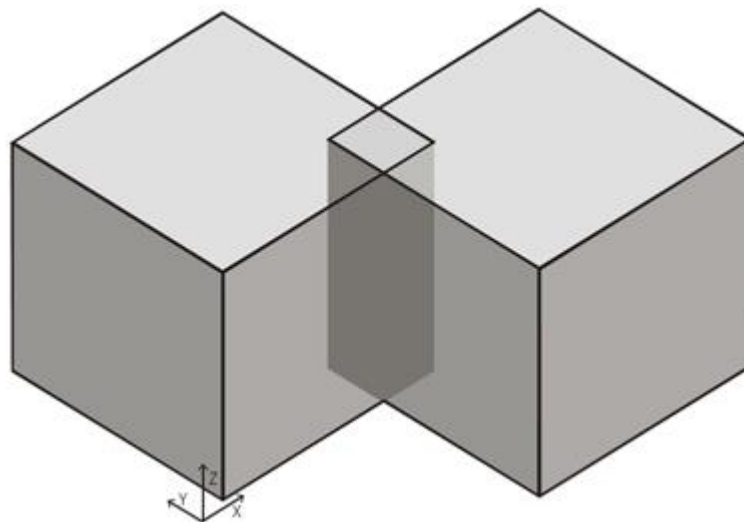

Hollow models

Whenever possible, you should make your models hollow (figure 4). This way, the time it takes to print them, as well as the quantity of used material, will be a lot less. This recommendation is particularly relevant if you're modelling relatively large objects.

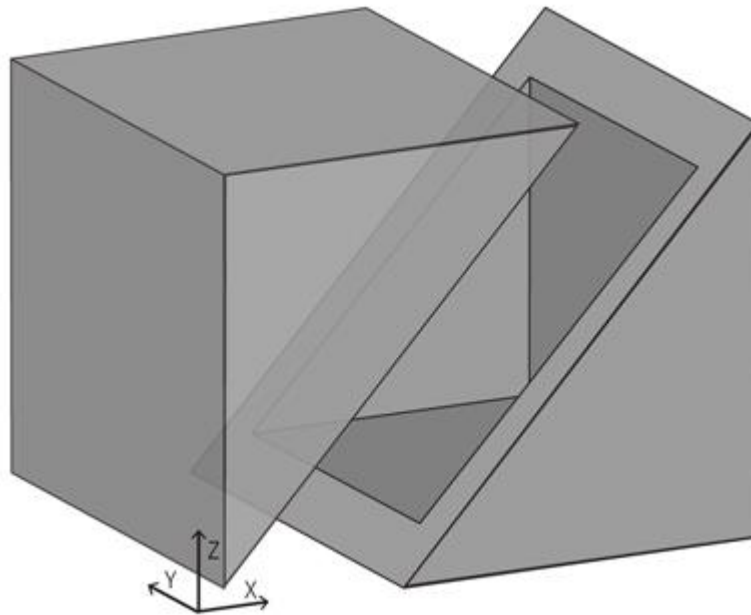

Moving parts

If the 3D models have moving parts, you should leave a space of at least 0.5mm between them, so that the parts do not get glued together and allow the desired movement (figure 5).

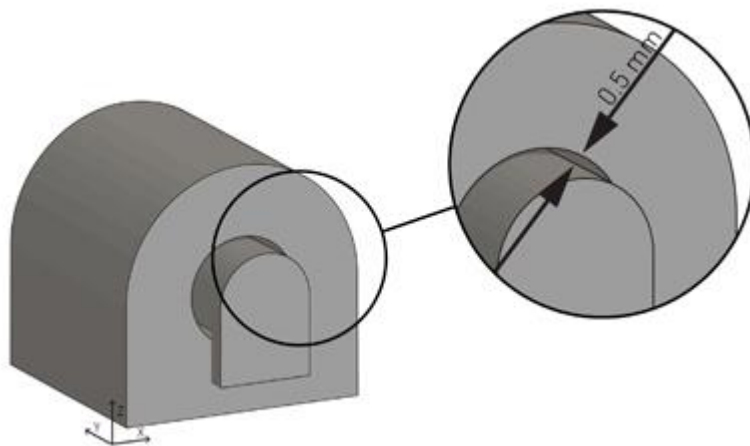

Minimum and maximum dimensions

The minimum advised printing size is 1mm x 1mm x 1mm.

Examples: A wall should not be less than 1mm thick (see figure 6) and a slab should not be less than 1mm high (see figure 7).

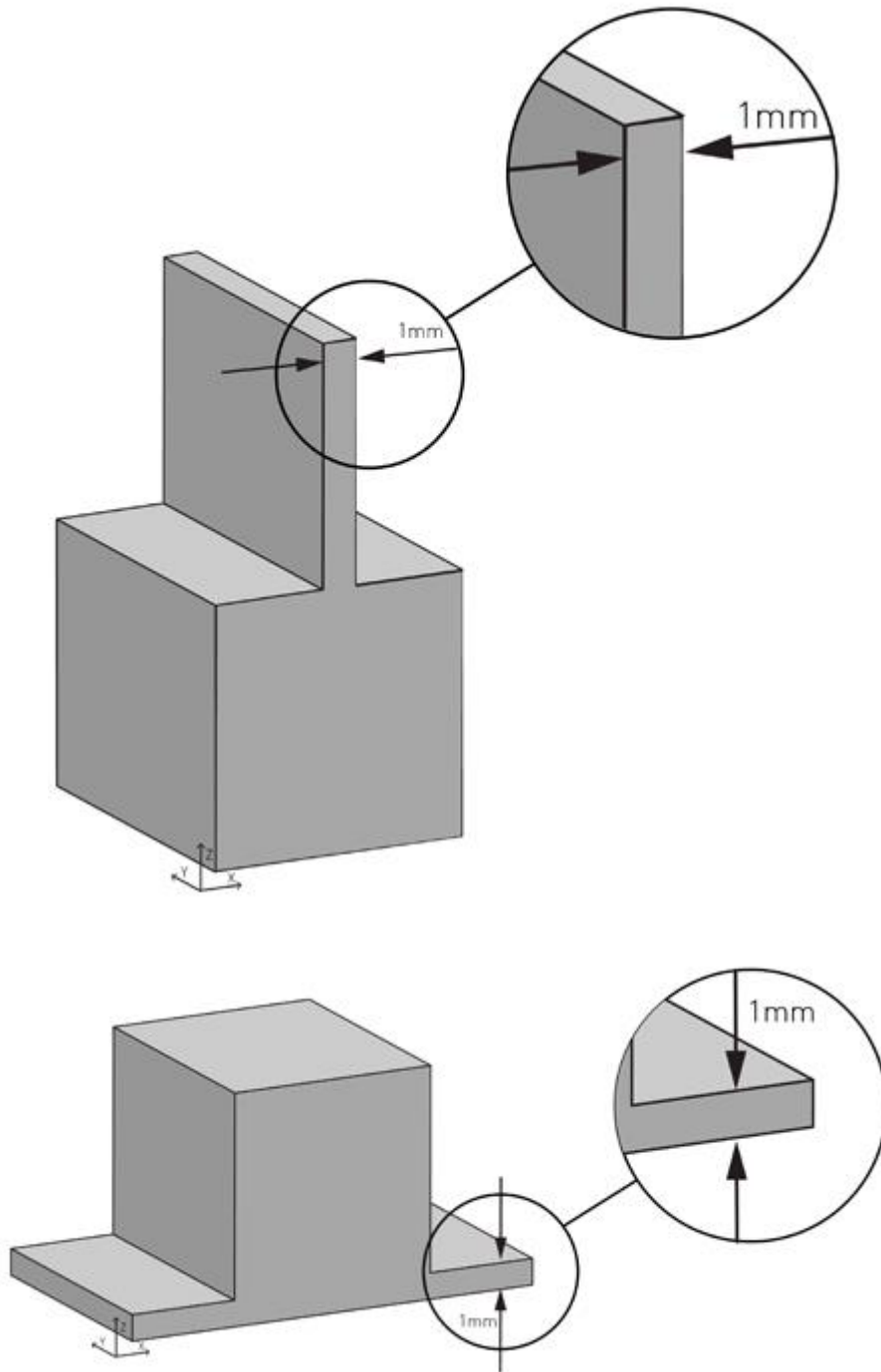

The maximum size of the printing area is 190mm x 135mm x 125mm (7.48 in x 5.31 in 4.92 x in) (figure 8). If you still haven't completely mastered 3D modelling techniques for printing, we suggest you avoid using the full potential of the printer.

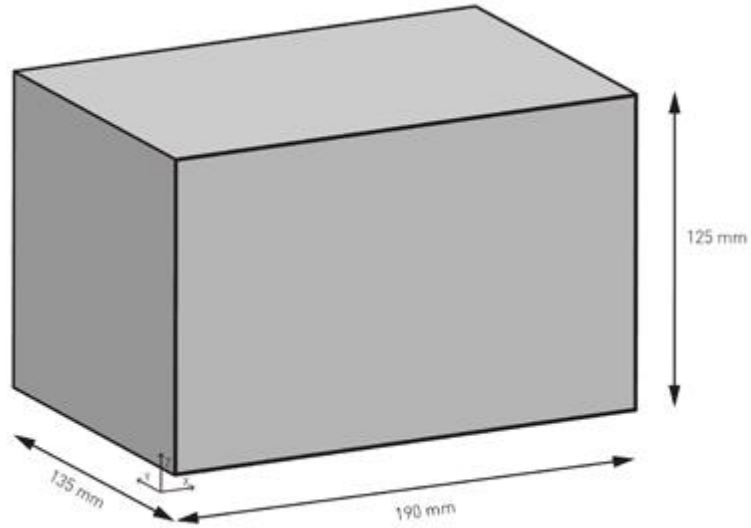

If you wish to print a 3D model that's larger in size than the allowed printing area, you should perhaps opt to divide the object into various components/parts and print them separately (figure 9). Alternatively, you might wish to resize the model, so that it can fit within the specified printing area (figure 10).

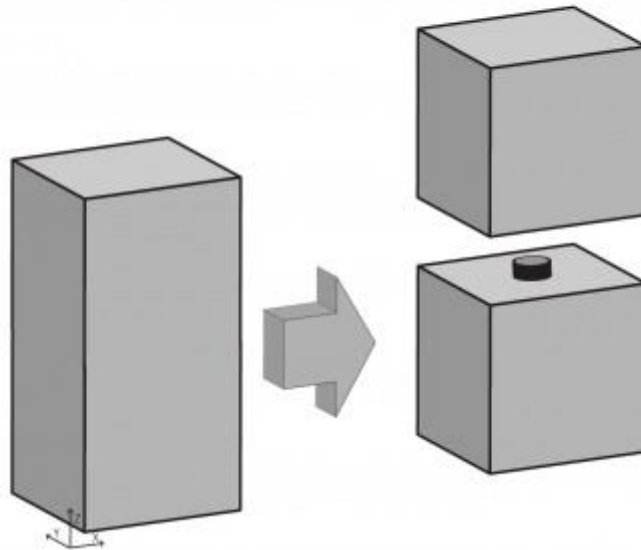

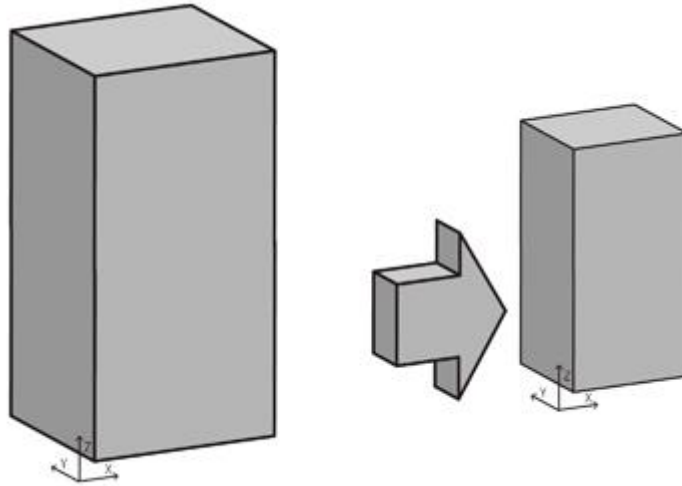

Flat base

All objects start to be printed by laying down thermoplastic on the surface of the 3D printing table. The object must have a flat base (or side) that will be the first part that's printed out. We advise that this surface has the minimum dimensions of 20mm x 20mm (0.8 in x 0.8 in) (figure 11).

During printing, the forces exerted in the X and Y axes may cause the object to become loose from the table. Should this happen, you must abort the current printing task. If the object has a base that's smaller than the one advised, the probability of it becoming separated from the table is higher.

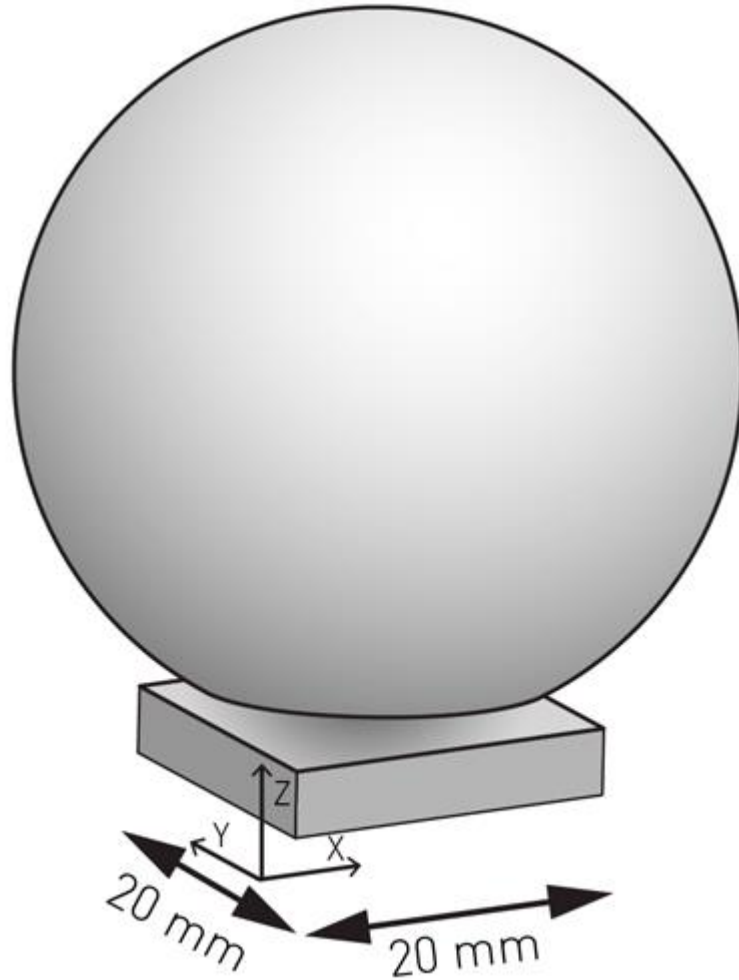

Bridges and overhangs

3D desktop printing is done through a process of depositing thermoplastic. For this to happen, the deposition must occur over the layer that's been previously laid down. Analogous to a bridge, in 3D printing it isn't possible to print a bridge that's too long, since the central span of the bridge won't have a layer of thermoplastic directly below. However, it's still possible to print a bridge with a central span of acceptable quality of a length of up to 10mm (0.4 in) (figure 12).

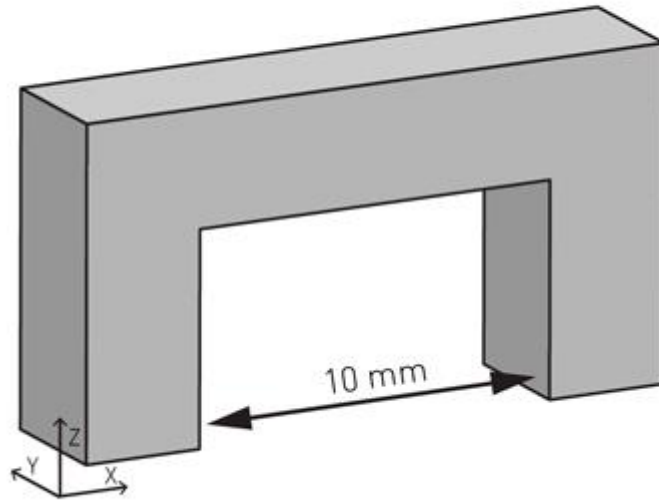

Whenever the 3D model has one or more overhangs that measure over 10mm (0.4 in), we advise you include a removable supporting element, so as to make it possible for them to be printed (figure 13).

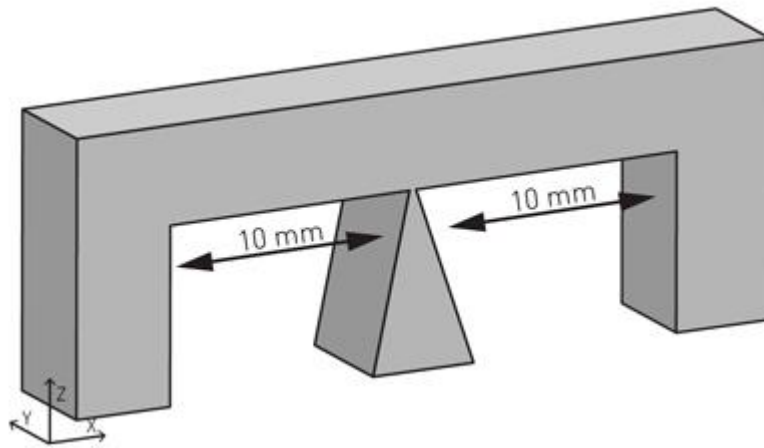

For the same reason, it isn't possible to print overhangs with an angle of less than 45 degrees (figure 14).

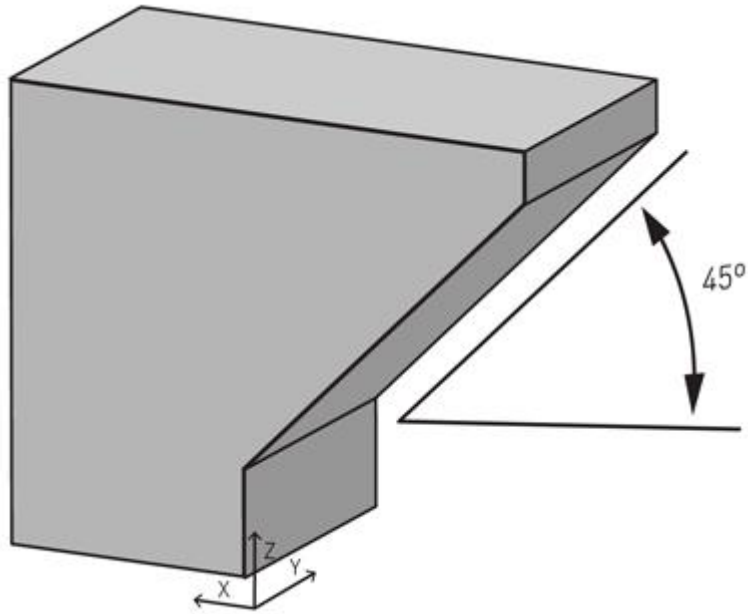

Round orifices laid parallel to the XY plane (figure 15) might be printed with some imperfections, since they include overhangs with angles less than 45 degrees and bridges with spans greater than 10mm (0.4 in) in length. We suggest the round orifices be adapted in such a way as to include two overhangs with 45-degree angles (figure 16).

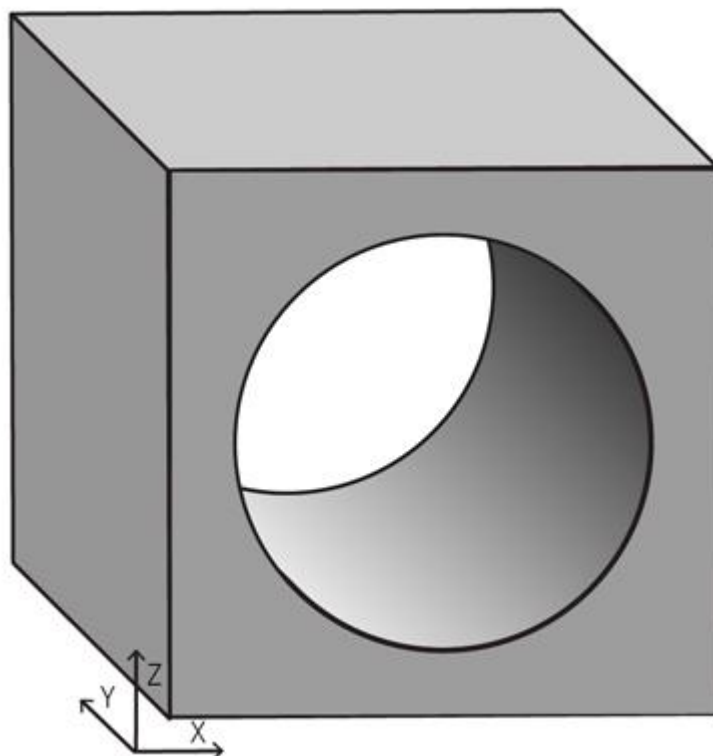

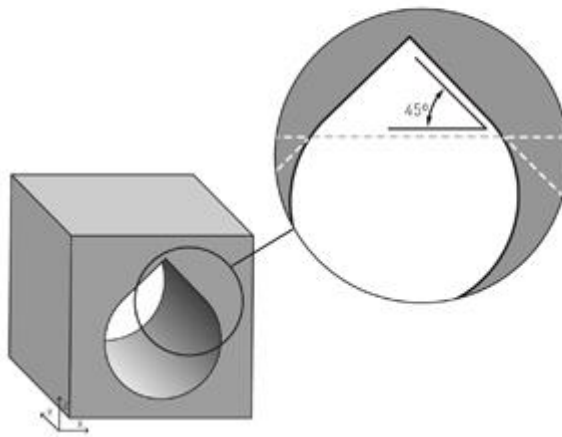

FEEDBACK

If you have any suggestions on how to improve this document, please contact [Customer Service](#).